

**10000 GALLON  
73" LL  
80" INLET**

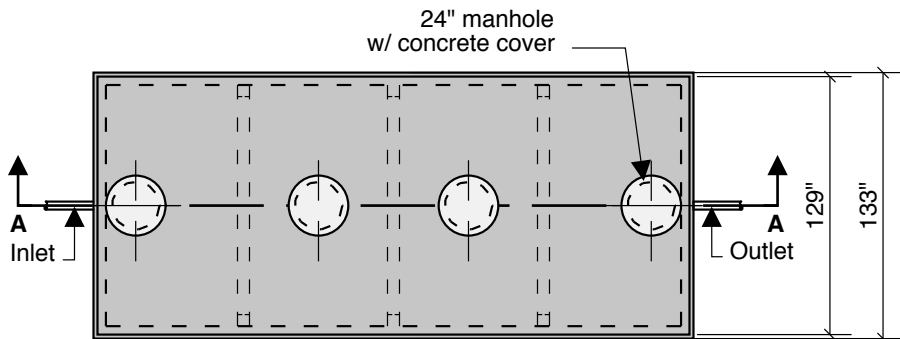

**Top View**

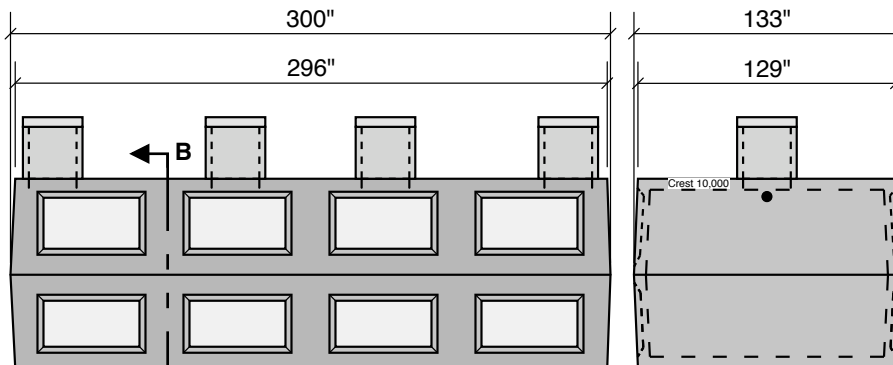

**Side View**

**End View**

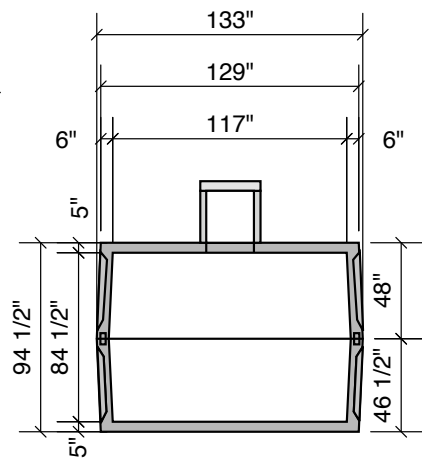

**SECTION B-B**

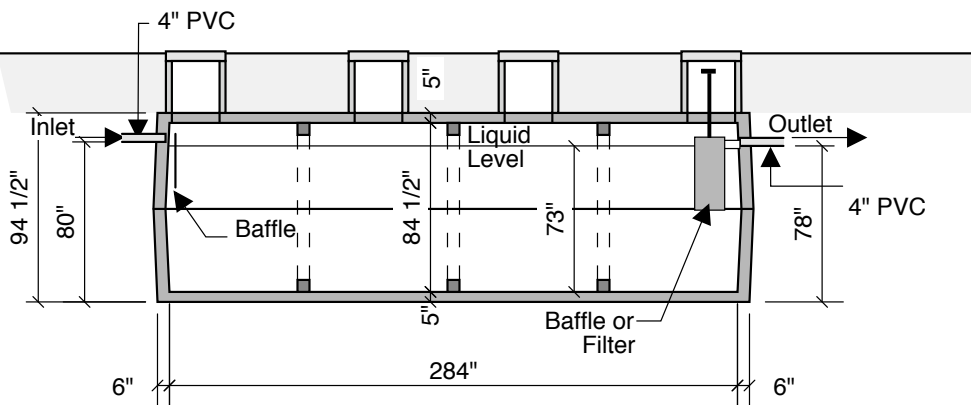

**Section A-A**

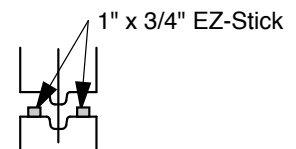

**Typical Tongue & Groove Joint**

Notes:  
Concrete - 5000 PSI  
Joint Sealant - High Grade EZ-Stick  
Labels - Warning signs located on all manholes  
Installation - See separate installation guide  
Baffles Installed  
Rubber Gaskets - Press Seal

Septic - Pump - Holding - Recirculation Or Grease Tank

**Crest Precast, Inc.**  
**La Crescent, MN & Barneveld, WI**  
800-658-9045

Scale		Drawn By:	KGT
Date		Revision	
<b>Project:</b>	<b>SEPTIC TANK 10,000 GALLON</b>		
<b>Contractor:</b>		Drawing Number	<b>MODEL 10000</b>